

W1

Weight Balanced
2 Paddle

Control Guide

Auto-Balance tension adjustment utilizes the weight of the user to balance resistance of the back. 3:1 back to seat synchronous movement with 2 position back lock.

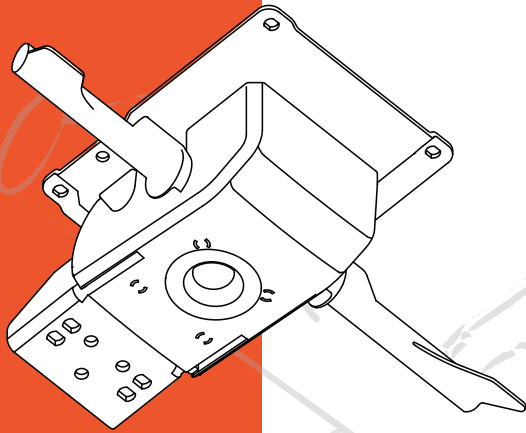

Back Multi-Lock W/ Safety Release:

Gently apply pressure to lock while seated, lift the lever up to release the back. Angle the back into one of the 2 lock position then push the lever down to lock the back into place.

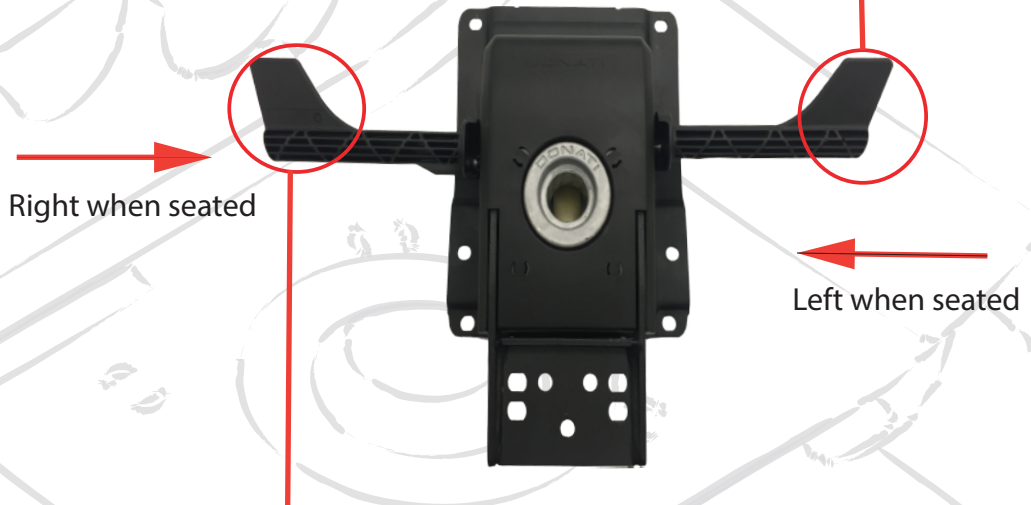

Seat Height Lever:

Lift and hold the lever to raise the seat. Release the lever to lock at the desired height. Lift and hold lever while applying weight on seat to lower seat height.